

IP & Wi-Fi Video Monitor

IPI-MON-7-V1

IPI-MON-7-V1

IP & WI-FI VIDEO MONITOR

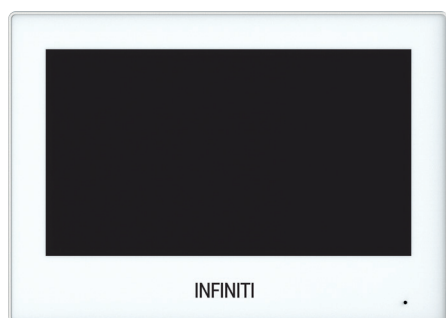

- 7" TFT capacitive touch screen, 1024 × 600
- 6-channel alarm input and 1-channel alarm output
- Wi-Fi
- Standard PoE
- Visitor call unit and security camera monitor
- H.265 and H.264 video decoding
- High performance & cost-effective



Technical Specification

System

Main Processor	Embedded processor
Operating System	Embedded Linux operating system
Interoperability	ONVIF; SDK
Network Protocol	RTSP; RTP; SIP; DNS; SSH
ROM	128 MB
RAM	128 MB
CPU	Dual core 1.2 GHz

Basic

Screen Type	Capacitive Touchscreen
Display	7" TFT
Screen Resolution	1024 × 600
Audio Compression	G.711a; G.711u; PCM
Audio Input	1
Audio Output	Built-in speaker
Audio Mode	2-way Audio
Audio Enhancement	Echo suppression
Audio Bit Rate	116 bit

Function

Communication Mode	Full digital
Notification	Receive and view text information sent by the property manager
DND Mode	Do not disturb period can be set; Do not disturb mode

Number of Extensions	Villa mode: 9 Flat: 4 Wi-Fi intercom: 1 main monitor, 2 extension monitors
Wi-Fi	Yes
Wireless Standard	IEEE802.11b/802.11g/802.11n
Wireless Frequency Range	2,412–2,472 MHz
Wireless Security Encryption	WPA/WPA2; WPA-PSK/WPA2-PSK
Performance	
Casing	PC + ABS
Port	
Alarm Input	6
Alarm Output	1
Door Bell	Yes (use any alarm input port)
Network	One 10 /100 Mbps Ethernet
General	
Appearance Color	Black/White
Power Supply	12 VDC 1A; Standard PoE (36–57 V, 0.35 A)
Installation	Surface Mount
Certifications	CE; FCC
Dimensions	189.6 mm × 134.6 mm × 26.0 mm (7.50" × 5.30" × 1.00")
Operating Temperature	–10 °C to +55 °C (+14 °F to 131 °F)
Operating Humidity	10%–95% RH (non-condensing)
Operating Altitude	Beneath 3,000 m (9,842.52 ft)
Power Consumption	Standby ≤ 2W; working ≤ 6W
Net Weight	0.34 kg (0.74 lb)
Gross Weight	0.58 kg (1.27 lb)

Installation

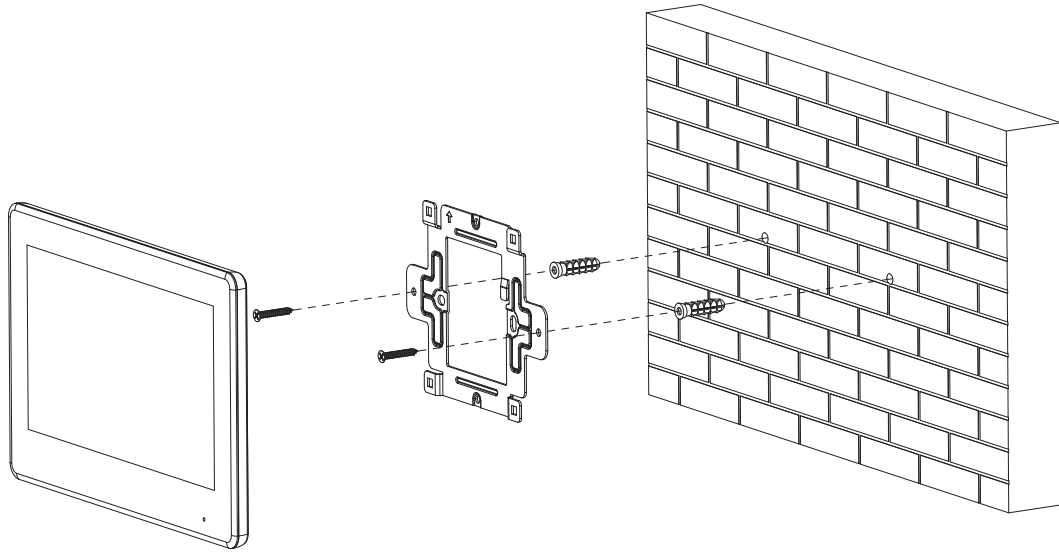

Dimensions (mm[inch])

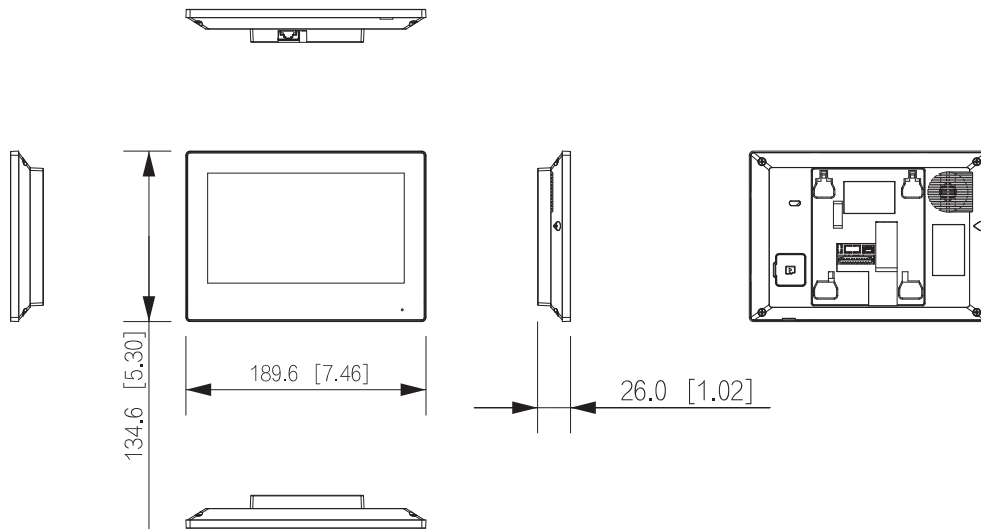

ACCESS ■ COMMUNICATIONS ■ CCTV

+44 (0)1442 211848
estimating@nacd.co.uk

www.nacd.co.uk
f in nacdltd

NACD Limited, 1 Enterprise Way,
Hemel Hempstead, HP2 7YJ

